

Recheck Torque After 50-100 Miles in Service		Torque Setting		ft/lbs
		Mileage of Unit Torqued		
<input type="checkbox"/>	<input type="checkbox"/>	<input type="checkbox"/>	<input type="checkbox"/>	<input type="checkbox"/>
<input type="checkbox"/>	<input type="checkbox"/>	<input type="checkbox"/>	<input type="checkbox"/>	<input type="checkbox"/>
<input type="checkbox"/>	<input type="checkbox"/>	<input type="checkbox"/>	<input type="checkbox"/>	<input type="checkbox"/>
<input type="checkbox"/>	<input type="checkbox"/>	<input type="checkbox"/>	<input type="checkbox"/>	<input type="checkbox"/>
Steer	Drive	Trailer		Place a "T" in each wheel position torqued.
Tech Signature & Svc ID#				
Customer/ Witness Signature				
Printed Customer/ Witness Name				

The Goodyear Tire & Rubber Company
GOODYEAR
 COMMERCIAL TIRE & SERVICE CENTERS
 820 33RD AVE SW
 CEDAR RAPIDS, IA 52404
 319-362-8289 Fax 319-366-3972

 1063648 BOL NO. 117-1063648 COPY 002

**BILL OF LADING
 FOR CUSTOMER APPROVAL AND PO
 NOT FOR FINAL BILLING**

Customer Info:

642887-0001
 TOOPS TRUCKING LLC DBA DMT EXP
 511 RAILROAD ST
 LITTLE YORK, IL 61453
 309-299-6803
 PO #: STOCK

BOL DATE: 04/23/2021
 DELIVERED TO CUSTOMER
 LOCATION/SREP: 117/DKB
 APPROVAL NUM :
 2021-04-23 11.59.52 DB
 CLERK: *** TECH: ***

QUANTITY	PRODUCT NO.	DESCRIPTION	FET	UNIT PRICE	T A X	AMOUNT	LINE #
		DELIVER 2 11R22.5 KELLY LHS					001
1	5180001	FUEL SURCHARGE		1.99		1.99	002
2	1571117	KS 11R22.5 ARMORSTL LHS 14	25.23*	319.00		688.46	003
2	9170000	IL TIRE USER FEE		2.50		5.00	004
							005

CUSTOMER BILLING REQUIREMENTS (GOODYEAR TIRE & RUBBER CO):
 WHEEL POSITION LOOSE
 MILEAGE (HUB/ODOMETER/HOURS)
 VIN # (LAST 6)
 REBILLING DR NUMBER
 FSSM #
 SERVICE TICKET NUMBER NA

The Tire Industry Association (TIA) recommends re-torque at 50-100 miles.

Disposal fees may apply in some areas.

Shop supply fees cover miscellaneous materials used in servicing your vehicle that do not appear elsewhere on this invoice and for profit.

TERMS:

SUB-TOTAL CONTINUED
 SALES TAX CONTINUED
 TOTAL AMOUNT PAYABLE IN U.S. FUNDS

No further discounts allowed. It is agreed that title to the above described property shall remain in the name of the seller until paid for in full, and that upon default in payment, seller shall be entitled to take possession thereof without notice to the purchaser.

If the total amount due is paid in full within terms, no FINANCE CHARGE will be incurred on that amount; otherwise, a FINANCE CHARGE will be computed on the previous balance after deducting payments and credit received during the current month. The FINANCE CHARGE is computed at a public rate of 0 . 8 2 5 0 0 which is an annual percentage rate of 9 . 9 0 0 0

Seller warrants that the tires are the size and tread design as stated above. SELLER MAKES NO OTHER WARRANTIES EITHER EXPRESSED OR IMPLIED, SPECIFICALLY SELLER MAKES NO WARRANTY OF MERCHANTABILITY OR FITNESS FOR ANY PARTICULAR PURPOSE. Seller's sole obligation to Buyer for nonconforming tires shall be a prorated refund of the tire's purchase price. Seller shall not be liable for any indirect, consequential or other damages. No person is authorized to modify or waive the limitations herein, whether orally or in writing. All claims and returned goods must be accompanied by this bill.

SIGNATURE

PULLED BY:	CHECKED OUT BY:

DO NOT PAY FROM THIS DOCUMENT.



120 Locations in 19 States, www.mhc.com

PARTS INVOICE

W100

SERVICING DEALERSHIP

IOWA KENWORTH, INC., DBA

MHC KENWORTH - QUAD CITIES

3600 78TH AVE WEST

ROCK ISLAND, IL 61201

1-309-787-6181

Customer No: 215887	Phone: (309) 299-6803	PO#:	Invoice No: T01135600135668
---------------------	-----------------------	------	-----------------------------

Tax Status	Terms	Truck ID	Counter Person	Invoice Date	Due Date
TAXABLE	CHARGE		JOHN H	4/29/2021	5/10/2021



S
O
L
D
T
O

Toops Trucking LLC
643 285th Ave
Alexis IL 61412-9157

S
H
I
P
T
O

DELIVER

Line	Part Number	Description	Ordered	B/O	Shipped	Each	Total
1	T71-1002	ABSORBER-S HOCK SLEE	2		2	59.40	118.80
2	KPNCB1221-Y212030	COUPON - ATRO TORQUE	1		1	5.00-	5.00-
3	TR00-41600ATR	TORQUE ROD , SMALL E	1		1	145.95	145.95

* Skip the Counter! Text us your part orders at 309-787-6181*
 * Online Parts Counter 7/24 Parts Ordering:
 * visit www.mhc.com for details *

SUBTOTAL	264.75
TAX 8.500 %	22.07
SUBLET	
OTHER	5.00-
SHIPPING	



TOTAL DUE	281.82
------------------	---------------

CUSTOMER AUTHORIZATION AND AGREEMENT

1. IMPORTANT: THIS PARTS ORDER AND INVOICE ("Order") CONSISTS OF THE TERMS EXPRESSLY SET FORTH HEREIN AND THE TERMS AND CONDITIONS SET FORTH AT WWW.MHC.COM/DEALERS/TERMS.HTM ("Terms and Conditions") Which are fully incorporated herein by this reference. Execution of this Order shall constitute Customer's agreement to the terms of this Order, including the Terms and Conditions. Customer acknowledges that, upon Customer's request, Customer may obtain a print-out of the Terms and Conditions from Dealer prior to executing this Order. Customer represents that Customer has had an opportunity to read and understand the terms of this Order, including the Terms and Conditions. Customer's acceptance of this Order is limited to Customer's execution of this order as required below, and no contract or agreement for the goods of and described herein ("Parts") will be formed except parts pursuant to and as permitted by this Order. This Order represents the entire and integrated agreement between the Customer and Dealer regarding the purchase and sale of the Parts and cancels and supersedes all prior negotiations, representations or agreements, either oral or written. Additional or substitute terms will not become part of this Order unless accepted in a writing signed by a corporate officer or authorized manager of Dealer.

2. Returns: Any parts or cores on this Order must be returned within 30 days. No return will be given without a copy of this Order.

3. Authority: The person(s) signing this Order for or on behalf of Customer hereby represents that he/she/they has full authority to bind Customer to this Order.

THIS ORDER CONTAINS A BINDING ARBITRATION PROVISION WHICH MAY BE ENFORCED BY THE PARTIES.

REMIT TO:
P.O. BOX 879269
KANSAS CITY, MO 64187-9269

PAGE: 1



120 Locations in 19 States, www.mhc.com

*W900
plus now*

SERVICING DEALERSHIP

IOWA KENWORTH, INC., DBA
MHC KENWORTH - QUAD CITIES
3600 78TH AVE WEST
ROCK ISLAND, IL 61201
1-309-787-6181

PARTS INVOICE

Customer No: 215887	Phone: (309) 299-6803	PO#:	Invoice No: T01135600135488
----------------------------	------------------------------	-------------	------------------------------------

Tax Status	Terms	Truck ID	Counter Person	Invoice Date	Due Date
TAXABLE	CHARGE		DANIEL B	4/27/2021	5/10/2021



S
O
L
D
T
O

Toops Trucking LLC
643 285th Ave
Alexis IL 61412-9157

S
H
I
P
T
O

DELIVER

Line	Part Number	Description	Ordered	B/O	Shipped	Each	Total
1	TR00-41009AT	TORQUE ROD , SMALL E	1		1	140.03	140.03

* *Skip the Counter! Text us your part orders at 309-787-6181* *
 * * Online Parts Counter 7/24 Parts Ordering: * *
 * * visit www.mhc.com for details * *

SUBTOTAL	140.03
TAX 8.500 %	11.90
SUBLET	
OTHER	
SHIPPING	



TOTAL DUE	151.93
------------------	---------------

CUSTOMER AUTHORIZATION AND AGREEMENT

1. IMPORTANT: THIS PARTS ORDER AND INVOICE ("Order") CONSISTS OF THE TERMS EXPRESSLY SET FORTH HEREIN AND THE TERMS AND CONDITIONS SET FORTH AT WWW.MHC.COM/DEALERS/TERMS.HTM ("Terms and Conditions") Which are fully incorporated herein by this reference. Execution of this Order shall constitute Customer's agreement to the terms of this Order, including the Terms and Conditions. Customer acknowledges that, upon Customer's request, Customer may obtain a print-out of the Terms and Conditions from Dealer prior to executing this Order. Customer represents that Customer has had an opportunity to read and understand the terms of this Order, including the Terms and Conditions. Customer's acceptance of this Order is limited to Customer's execution of this order as required below, and no contract or agreement for the goods of and described herein ("Parts") will be formed except parts pursuant to and as permitted by this Order. This Order represents the entire and integrated agreement between the Customer and Dealer regarding the purchase and sale of the Parts and catenals and supersedes all prior negotiations, representations or agreements, either oral or written. Additional or substitute terms will not become part of this Order unless accepted in a writing signed by a corporate officer or authorized manager of Dealer.

2. Returns: Any parts or cores on this Order must be returned within 30 days. No return will be given without a copy of this Order.

3. Authority: The person(s) signing this Order for or on behalf of Customer hereby represents that he/she/they has full authority to bind Customer to this Order.

THIS ORDER CONTAINS A BINDING ARBITRATION PROVISION WHICH MAY BE ENFORCED BY THE PARTIES.

REMIT TO:
P.O. BOX 879269
KANSAS CITY, MO 64187-9269

STATEMENT OF ACCOUNT



MHC KENWORTH - QUAD CITIES
 3600 78TH AVE WEST
 ROCK ISLAND, IL 61201
 (309) 787-6181

Toops Trucking LLC
 643 285th Ave
 Alexis, IL 61412 -9157

Account No.	Stmt Date	Terms	Page
215887	5/01/2021	NET 10TH	1

INVOICE DATE	ACTIVITY	INVOICE NUMBER	REFERENCE #	CHARGES	CREDITS	BALANCE
1/02/2021	CREDIT	M01135600027105			-251.75	-251.75
4/27/2021	SALE	T01135600135488		151.93		-99.82
4/29/2021	SALE	T01135600135668		281.82		182.00
	**TOTAL	MHC KENWORTH - QUAD CITIES				182.00

ACCOUNT STATUS	BALANCE DUE	PAST DUE	CURRENT DUE	31 - 60 DAYS	61 - 90 DAYS	91 - 120 DAYS	OVER 120 DAYS
	182.00	.00	182.00	.00	.00	.00	.00

A PENALTY CHARGE, if any, is 1 1/2 percent of the past due balance which is an ANNUAL PERCENTAGE RATE of 18%

PAYMENT SLIP For *Toops Trucking LLC*

REMIT TO:



STATEMENT DATE: 5/01/2021
 ACCOUNT NUMBER: 215887

AMOUNT DUE: 182.00

MHC KENWORTH - QUAD CITIES
 P.O. BOX 879269
 KANSAS CITY, MO 64187 -9269

AMOUNT ENCLOSED:



(To assure proper credit please detach and use this PAYMENT SLIP and return with remittance)

DMT Express, Inc.

Driver's Vehicle Inspection Report

One report should be turned in weekly for each truck.

Truck #: ¹⁸¹~~107~~

Odometer: ~~75878~~ 433698

Sunday - Date: off

Condition of vehicle is satisfactory

Vehicle has defects

List defects: _____

Repairs made: _____

Monday - Date: 4/26/21

Condition of vehicle is satisfactory

Vehicle has defects

List defects: _____

Repairs made: _____

Tuesday - Date: 4/27/21

Condition of vehicle is satisfactory

Vehicle has defects

List defects: _____

Repairs made: _____

Wednesday - Date: 4/28/21

Condition of vehicle is satisfactory

Vehicle has defects

List defects: _____

Repairs made: _____

Thursday - Date: 4/29/21

Condition of vehicle is satisfactory

Vehicle has defects

List defects: _____

Repairs made: _____

Friday - Date: 4/30/21

Condition of vehicle is satisfactory

Vehicle has defects

List defects: _____

Repairs made: _____

Saturday - Date: 5/1/21

Condition of vehicle is satisfactory

Vehicle has defects

List defects: _____

Repairs made: _____

End of week odometer reading: 437208

Driver Signature: [Signature]

DMT EXPRESS, INC. or TOOPS TRUCKING, LLC

MAINTENANCE/REPAIR REQUEST FORM

Driver's Name: Tom Belling Date: 5/8/21

Truck or Trailer number needing work: 181 Mileage: 439500

Work to be performed or issues that are occurring: Oil Change
Takes 1st stage Not working

Done

Inspection, Repair & Maintenance Record

VEHICLE IDENTIFICATION

Kenworth
Make & Model

Truck # 181
Unit No.

Year

Serial No.

DATE	OPERATION PERFORMED, INSPECTION AND/OR REPAIR
5-10-21	
	greased
	adjusted Brakes
	changed oil & filter
	changed fuel filters
	checked Trans & Rear ends

WORK PERFORMED BY: _____

Warren County Mobile Repair

Invoice

630 Railroad St
 P O Box 148
 Little York, IL 61453

Date	Invoice #
5/10/2021	4344

Bill To
Toops Trucking 643 285 Ave Alexis, IL 61412

Ship To

VIN	MILES			Ship	YEAR	
		Due on receipt		5/10/2021		

Quantity	Item Code	Description	Price Each	Amount
1	489XLAHX-A3XQ	PTO	629.11	629.11T
1	C102D-25-1	HYDRO PUMP	562.55	562.55T
1	PB10	PTO BRACKET	53.69	53.69T
1	3239-8	TOWER	36.66	36.66T
1	AV295	PTO CONTROL	174.42	174.42T
			Subtotal	\$1,456.43
			Sales Tax (7.25%)	\$105.59
			Total	\$1,562.02

Phone #	Fax #
309 729 1160	309 729 1161

Warren County Mobile Repair

Invoice

630 Railroad St
 P O Box 148
 Little York, IL 61453

Date	Invoice #
5/18/2021	4351

Bill To
DMT Express 643 285 Ave Alexis, IL 61412

Ship To
DMT Express P.o. Box 316 Monmouth, IL 61462

VIN	MILES			Ship	YEAR	
				5/18/2021		

Quantity	Item Code	Description	Price Each	Amount
2	labor	CHECKED JAKE BRAKE FOR NOT WORKING ON LOW STAGE, WIRING CHECKED OK, REMOVED VALVE COVER AND FOUND BLOWN O-RING, REPLACED O-RING AND TESTED.. REPAIR MADE TO W900 KENWORTH	65.00	130.00
2	23-13201-000	SEAL	2.76	5.52T
			Subtotal	\$135.52
			Sales Tax (7.25%)	\$0.40
			Total	\$135.92

Phone #	Fax #
309 729 1160	309 729 1161

DMT Express, Inc.

Driver's Vehicle Inspection Report

One report should be turned in weekly for each truck.

Truck #: 181

Odometer: 437 208

Sunday - Date: Off

Condition of vehicle is satisfactory

Vehicle has defects

List defects: _____

Repairs made: _____

Monday - Date: 5/3/21

Condition of vehicle is satisfactory

Vehicle has defects

List defects: _____

Repairs made: _____

Tuesday - Date: 5/4/21

Condition of vehicle is satisfactory

Vehicle has defects

List defects: _____

Repairs made: _____

Wednesday - Date: 5/5/21

Condition of vehicle is satisfactory

Vehicle has defects

List defects: _____

Repairs made: _____

Thursday - Date: 5/6/21

Condition of vehicle is satisfactory

Vehicle has defects

List defects: _____

Repairs made: _____

Friday - Date: 5/7/21

Condition of vehicle is satisfactory

Vehicle has defects

List defects: _____

Repairs made: _____

Saturday - Date: 5/8/21

Condition of vehicle is satisfactory

Vehicle has defects

List defects: _____

Repairs made: _____

End of week odometer reading: 439 813

Driver Signature: [Signature]

Odometer Broke
Roughly

3556 mi

DMT Express, Inc.

Driver's Vehicle Inspection Report

One report should be turned in weekly for each truck.

Truck #: 181

Odometer: 439813

Sunday - Date: 5/9/21 off

Condition of vehicle is satisfactory

Vehicle has defects

List defects: _____

Repairs made: _____

Monday - Date: 5/10/21

Condition of vehicle is satisfactory

Vehicle has defects

List defects: _____

Repairs made: _____

Tuesday - Date: 5/11/21

Condition of vehicle is satisfactory

Vehicle has defects

List defects: _____

Repairs made: _____

Wednesday - Date: 5/12/21

Condition of vehicle is satisfactory

Vehicle has defects

List defects: _____

Repairs made: _____

Thursday - Date: 5/13/21

Condition of vehicle is satisfactory

Vehicle has defects

List defects: _____

Repairs made: _____

Friday - Date: 5/14/21

Condition of vehicle is satisfactory

Vehicle has defects

List defects: _____

Repairs made: _____

Saturday - Date: off

Condition of vehicle is satisfactory

Vehicle has defects

List defects: _____

Repairs made: _____

End of week odometer reading: 442063

Driver Signature: [Signature]

DMT Express, Inc.

Driver's Vehicle Inspection Report

One report should be turned in weekly for each truck.

Truck #: 181

Odometer: 442063

Sunday - Date: off

Condition of vehicle is satisfactory

Vehicle has defects

List defects: _____

Repairs made: _____

Monday - Date: 5/17/21

Condition of vehicle is satisfactory

Vehicle has defects

List defects: _____

Repairs made: _____

Tuesday - Date: 5/18/21

Condition of vehicle is satisfactory

Vehicle has defects

List defects: _____

Repairs made: _____

Wednesday - Date: 5/19/21

Condition of vehicle is satisfactory

Vehicle has defects

List defects: _____

Repairs made: _____

Thursday - Date: 5/20/21

Condition of vehicle is satisfactory

Vehicle has defects

List defects: _____

Repairs made: _____

Friday - Date: 5/21/21

Condition of vehicle is satisfactory

Vehicle has defects

List defects: _____

Repairs made: _____

Saturday - Date: 5/22/21

Condition of vehicle is satisfactory

Vehicle has defects

List defects: _____

Repairs made: _____

End of week odometer reading: 443889

Driver Signature: [Signature]

nvc

DMT Express, Inc.

Driver's Vehicle Inspection Report

One report should be turned in weekly for each truck.

Truck #: 181

Odometer: 443889

Sunday - Date: 5/23/21

Condition of vehicle is satisfactory

Vehicle has defects

List defects: _____

Repairs made: _____

Monday - Date: 5/24/21

Condition of vehicle is satisfactory

Vehicle has defects

List defects: _____

Repairs made: _____

Tuesday - Date: OFF

Condition of vehicle is satisfactory

Vehicle has defects

List defects: _____

Repairs made: _____

Wednesday - Date: OFF

Condition of vehicle is satisfactory

Vehicle has defects

List defects: _____

Repairs made: _____

Thursday - Date: 5/27/21

Condition of vehicle is satisfactory

Vehicle has defects

List defects: _____

Repairs made: _____

Friday - Date: 5/28/21

Condition of vehicle is satisfactory

Vehicle has defects

List defects: _____

Repairs made: _____

Saturday - Date: OFF

Condition of vehicle is satisfactory

Vehicle has defects

List defects: _____

Repairs made: _____

End of week odometer reading: 445245

3335685

Driver Signature: 

m

AUTO REPAIR ORDER

11844

Quick Fix 24 Hour Mobile Mechanic, LLC
 13430 Veteran's Memorial Parkway
 Wright City, MO 63390
 636-357-9088

NAME: **DMT Express**
 ADDRESS:
 CITY:

QUAN.	PART NO.	NAME OF PART	SALE AMT.	CUSTOMER'S INFORMATION			
1		QRIC Valve	69.99	DATE	CUSTOMER'S ORDER NO.	WHEN PROMISED	PHONE
				6-14-21			
				YEAR MAKE • MODEL		SERIAL NO.	
				Truck # 181		MOTOR NO.	
				LICENSE NO.	MILEAGE	WRITTEN BY	
						Dustin	
				<input type="checkbox"/> LUBE	<input type="checkbox"/> OIL CHANGE	<input type="checkbox"/> FLUSH TRANS.	<input type="checkbox"/> FLUSH DIFF.
				<input type="checkbox"/> WASH	<input type="checkbox"/> POLISH		
				Service call to Truck # 181 with Air Leak at Foliq Mission. Truck stop to unit. Arrived to unit and identified leaking QRIC Valve. Removed and replaced. Verified repair.			
				GAS, OIL & GREASE		ACCESSORIES	LABOR ONLY
				GALS. GAS			315.00
				QTS. OIL			69.99
				LBS. GREASE			15.95
				TOTAL GAS OIL & GREASE			
				<input type="checkbox"/> RETAIN PARTS			
				<input type="checkbox"/> DESTROY PARTS			
				TOTAL ACCESSORIES			
				AUTHORIZED BY			
				ESTIMATE AMOUNT • PARTS & LABOR			
						TAX	5.93
						Service Call	65.00
						TOTAL	471.87

I HEREBY AUTHORIZE THE ABOVE REPAIR WORK TO BE DONE ALONG WITH THE NECESSARY MATERIAL, AND HEREBY GRANT YOU AND/OR YOUR EMPLOYEES PERMISSION TO OPERATE THE CAR, TRUCK OR VEHICLE HEREIN DESCRIBED ON STREETS, HIGHWAYS OR ELSEWHERE FOR THE PURPOSE OF TESTING AND/OR INSPECTION. AN EXPRESS MECHANIC'S LIEN IS HEREBY ACKNOWLEDGED ON ABOVE CAR, TRUCK OR VEHICLE TO SECURE THE AMOUNT OF THE REPAIRS THERETO.

Auto Repair Order

DMT Express, Inc.

Driver's Vehicle Inspection Report

One report should be turned in weekly for each truck.

Truck #: 1811

Odometer: 447 775

Sunday - Date: Off

Condition of vehicle is satisfactory

Vehicle has defects

List defects: _____

Repairs made: _____

Monday - Date: 6/14/21

Condition of vehicle is satisfactory

Vehicle has defects

List defects: _____

Repairs made: _____

Tuesday - Date: 6/15/21

Condition of vehicle is satisfactory

Vehicle has defects

List defects: _____

Repairs made: _____

Wednesday - Date: 6/16/21

Condition of vehicle is satisfactory

Vehicle has defects

List defects: _____

Repairs made: _____

Thursday - Date: 6/17/21

Condition of vehicle is satisfactory

Vehicle has defects

List defects: _____

Repairs made: _____

Friday - Date: 6/18/21

Condition of vehicle is satisfactory

Vehicle has defects

List defects: _____

Repairs made: _____

Saturday - Date: Off

Condition of vehicle is satisfactory

Vehicle has defects

List defects: _____

Repairs made: _____

End of week odometer reading: 450 134

Driver Signature: [Signature]

GPS 3204

DMT EXPRESS, INC. or TOOPS TRUCKING, LLC

MAINTENANCE ORDER FORM

Driver's Name: Matt Date: 8/13/21

Truck or Trailer Number needing work: Truck # 181 Mileage: _____

Work to be performed or issues that are occurring: all new shocks

Done

DMT Express, Inc.
Driver's Vehicle Inspection Report
One report should be turned in weekly for each truck.

Truck #: 181

Odometer: 452659

Sunday - Date: OFF

Condition of vehicle is satisfactory

Vehicle has defects

List defects: _____

Repairs made: _____

Monday - Date: 6/28/21

Condition of vehicle is satisfactory

Vehicle has defects

List defects: _____

Repairs made: _____

Tuesday - Date: 6/29/21

Condition of vehicle is satisfactory

Vehicle has defects

List defects: _____

Repairs made: _____

Wednesday - Date: 6/30/21

Condition of vehicle is satisfactory

Vehicle has defects

List defects: _____

Repairs made: _____

Thursday - Date: OFF

Condition of vehicle is satisfactory

Vehicle has defects

List defects: _____

Repairs made: _____

Friday - Date: OFF

Condition of vehicle is satisfactory

Vehicle has defects

List defects: _____

Repairs made: _____

Saturday - Date: OFF

Condition of vehicle is satisfactory

Vehicle has defects

List defects: _____

Repairs made: _____

End of week odometer reading: 453570

Driver Signature: 

1866 GPS miles



AAP OF MONMOUTH # 2763
 918 S MAIN ST
 MONMOUTH, IL 61462
 309-734-7946

PAGE 1 OF 1
 REF# 634252

REMIT TO: ADVANCE AUTO PARTS
 PO BOX 404875
 ATLANTA, GA 30384-4875



B TOOPS TRUCKING, LLC
 L 643 - 285TH AVENUE
 T ALEXIS, IL 61412
 O

S TOOPS TRUCKING, LLC
 I 643 - 285TH AVENUE
 T ALEXIS, IL 61412
 O

INVOICE NO.	CUSTOMER NO.	DATE	CUST. P.O. NO.		SALES ID	TEAMMATE ID	FORM OF PYMT.	
7595-415217	2525800	7/1/2021	TRK# 181			CB1399		
MFG. PART NUMBER			ORDERED	SHIPPED	LIST PRICE	NET	NET CORE	CHARGE
1	BON 932		1	1	14.09	8.24	0.00	8.24 N/N
	BODY PATCH							
2	JB 8272		1	1	10.99	7.18	0.00	7.18 N/N
	JB WELD MARINE WELD EPOXY							
3	JB 8272		1	1	10.99	7.18	0.00	7.18 N/N
	JB WELD MARINE WELD EPOXY							
SHIP VIA	DELV. TIME	DELV. ID	FREIGHT	TAXABLE AMT.	SALES TAX	TOTAL CORE	PREV. DEPOSIT	
	05:30 PM			0.00	0.00			

RECEIVED BY X

CUSTOMER COPY

PAY THIS AMOUNT

22.60

AAPEX101

DMT Express, Inc.
Driver's Vehicle Inspection Report
One report should be turned in weekly for each truck.

Truck #: 181

Odometer: 453570

Sunday - Date: ORR

Condition of vehicle is satisfactory

Vehicle has defects

List defects: _____

Repairs made: _____

Monday - Date: ORR

Condition of vehicle is satisfactory

Vehicle has defects

List defects: _____

Repairs made: _____

Tuesday - Date: 7/6/21

Condition of vehicle is satisfactory

Vehicle has defects

List defects: _____

Repairs made: _____

Wednesday - Date: 7/7/21

Condition of vehicle is satisfactory

Vehicle has defects

List defects: _____

Repairs made: _____

Thursday - Date: 7/8/21

Condition of vehicle is satisfactory

Vehicle has defects

List defects: _____

Repairs made: _____

Friday - Date: 7/9/21

Condition of vehicle is satisfactory

Vehicle has defects

List defects: _____

Repairs made: _____

Saturday - Date: 7/10/21

Condition of vehicle is satisfactory

Vehicle has defects

List defects: _____

Repairs made: _____

End of week odometer reading: 456835

Driver Signature: [Signature]

DMT Express, Inc.
Driver's Vehicle Inspection Report
One report should be turned in weekly for each truck.

Truck #: 181

Odometer: 456055

Sunday - Date: OFF

Condition of vehicle is satisfactory

Vehicle has defects

List defects: _____

Repairs made: _____

Monday - Date: 7/12/21

Condition of vehicle is satisfactory

Vehicle has defects

List defects: _____

Repairs made: _____

Tuesday - Date: 7/13/21

Condition of vehicle is satisfactory

Vehicle has defects

List defects: _____

Repairs made: _____

Wednesday - Date: 7/14/21

Condition of vehicle is satisfactory

Vehicle has defects

List defects: _____

Repairs made: _____

Thursday - Date: 7/15/21

Condition of vehicle is satisfactory

Vehicle has defects

List defects: _____

Repairs made: _____

Friday - Date: OFF

Condition of vehicle is satisfactory

Vehicle has defects

List defects: _____

Repairs made: _____

Saturday - Date: OFF

Condition of vehicle is satisfactory

Vehicle has defects

List defects: _____

Repairs made: _____

End of week odometer reading: 458207

GPS 2350

Driver Signature: _____

DMT Express, Inc.
Driver's Vehicle Inspection Report
One report should be turned in weekly for each truck.

Truck #: 181

Odometer: 458207

Sunday - Date: 7/18/21

Condition of vehicle is satisfactory

Vehicle has defects

List defects: _____

Repairs made: _____

Monday - Date: 7/19/21

Condition of vehicle is satisfactory

Vehicle has defects

List defects: _____

Repairs made: _____

Tuesday - Date: 7/20/21

Condition of vehicle is satisfactory

Vehicle has defects

List defects: _____

Repairs made: _____

Wednesday - Date: off

Condition of vehicle is satisfactory

Vehicle has defects

List defects: _____

Repairs made: _____

Thursday - Date: off

Condition of vehicle is satisfactory

Vehicle has defects

List defects: _____

Repairs made: _____

Friday - Date: off

Condition of vehicle is satisfactory

Vehicle has defects

List defects: _____

Repairs made: _____

Saturday - Date: off

Condition of vehicle is satisfactory

Vehicle has defects

List defects: _____

Repairs made: _____

End of week odometer reading: 459786

Driver Signature: 

2005 6BS

Inspection, Repair & Maintenance Record

VEHICLE IDENTIFICATION

Make & Model

Unit No.

Truck # 181

Year

Serial No.

DATE	OPERATION PERFORMED, INSPECTION AND/OR REPAIR
7-26-21	Change oil & filter
	change fuel filters
	adjusted Brakes
	greased

WORK PERFORMED BY: _____

DMT Express, Inc.
Driver's Vehicle Inspection Report
One report should be turned in weekly for each truck.

Truck #: 181

Odometer: 45-9786

Sunday - Date: off

Condition of vehicle is satisfactory

Vehicle has defects

List defects: _____

Repairs made: _____

Monday - Date: 7/26/21

Condition of vehicle is satisfactory

Vehicle has defects

List defects: _____

Repairs made: _____

Tuesday - Date: 7/27/21

Condition of vehicle is satisfactory

Vehicle has defects

List defects: _____

Repairs made: _____

Wednesday - Date: 7/28/21

Condition of vehicle is satisfactory

Vehicle has defects

List defects: _____

Repairs made: _____

Thursday - Date: 7/29/21

Condition of vehicle is satisfactory

Vehicle has defects

List defects: _____

Repairs made: _____

Friday - Date: 7/30/21

Condition of vehicle is satisfactory

Vehicle has defects

List defects: _____

Repairs made: _____

Saturday - Date: 7/31/21

Condition of vehicle is satisfactory

Vehicle has defects

List defects: _____

Repairs made: _____

End of week odometer reading: 462434

Driver Signature: [Signature]

3480



120+ Locations in 19 states, mhc.com

SERVICING DEALERSHIP

IOWA KENWORTH, INC., DBA

MHC KENWORTH - QUAD CITIES

3600 78TH AVE WEST

ROCK ISLAND, IL 61201

1-309-787-6181

PARTS INVOICE

Customer No: 215887	Phone: (309) 299-6803	PO#:	Invoice No: T01135600141018
---------------------	-----------------------	------	-----------------------------

Tax Status	Terms	Truck ID	Counter Person	Invoice Date	Due Date
TAXABLE	CHARGE	070506	JIM E	7/27/2021	8/10/2021



S
O
L
D
T
O

Toops Trucking LLC
643 285th Ave
Alexis IL 61412-9157

S
H
I
P
T
O

DELIVER

Line	Part Number	Description	Ordered	B/O	Shipped	Each	Total
1	10200-00BWS	ARM-ELECTR IC WINDSH	1		1	87.73	87.73
2	RFK161-793-22	LINING-TAN K STRAP	4		4	21.66	86.64
3	RFK161-934-11	LINING	4		4	34.09	136.36

Truck #181

* *Skip the Counter! Text us your part orders at 309-787-6181* *
 * * Online Parts Counter 7/24 Parts Ordering: * *
 * * visit www.mhc.com for details * *

SUBTOTAL	310.73
TAX 8.500 %	26.41
SUBLET	
OTHER	
SHIPPING	

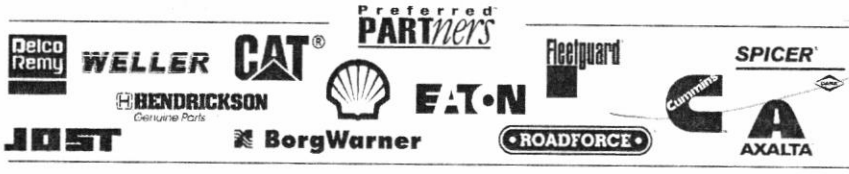

TOTAL DUE	337.14
------------------	---------------

CUSTOMER AUTHORIZATION AND AGREEMENT

1. IMPORTANT: THIS PARTS ORDER AND INVOICE ("Order") CONSISTS OF THE TERMS EXPRESSLY SET FORTH HEREIN AND THE TERMS AND CONDITIONS SET FORTH AT WWW.MHC.COM/DEALERS/TERMS.HTM ("Terms and Conditions") Which are fully incorporated herein by this reference. Execution of this Order shall constitute Customer's agreement to the terms of this Order, including the Terms and Conditions. Customer acknowledges that, upon Customer's request, Customer may obtain a print-out of the Terms and Conditions from Dealer prior to executing this Order. Customer represents that Customer has had an opportunity to read and understand the terms of this Order, including the Terms and Conditions. Customer's acceptance of this Order is limited to Customer's execution of this order as required below, and no contract or agreement for the goods of the Parts and cancels and supersedes all prior negotiations, representations or agreements, either oral or written. Additional or substitute terms will not become part of this Order unless accepted in a writing signed by a corporate officer or authorized manager of Dealer.

2. Returns: Any parts or cores on this Order must be returned within 30 days. No return will be given without a copy of this Order.

3. Authority: The person(s) signing this Order for or on behalf of Customer hereby represents that he/she/they has full authority to bind Customer to this Order.

THIS ORDER CONTAINS A BINDING ARBITRATION PROVISION WHICH MAY BE ENFORCED BY THE PARTIES.

PAY FROM THIS INVOICE
REMIT TO:
 P.O. BOX 879269
 KANSAS CITY, MO 64187-9269

9:17 CUSTOMER AUTHORIZED SIGNATURE _____

DMT Express, Inc.
Driver's Vehicle Inspection Report
One report should be turned in weekly for each truck.

Truck #: 8718

Odometer: 423245

Sunday - Date: _____

Condition of vehicle is satisfactory

Vehicle has defects

List defects: _____

Repairs made: _____

Monday - Date: _____

Condition of vehicle is satisfactory

Vehicle has defects

List defects: _____

Repairs made: _____

Tuesday - Date: _____

Condition of vehicle is satisfactory

Vehicle has defects

List defects: _____

Repairs made: _____

Wednesday - Date: _____

Condition of vehicle is satisfactory

Vehicle has defects

List defects: _____

Repairs made: _____

Thursday - Date: 8-5-21

Condition of vehicle is satisfactory

Vehicle has defects

List defects: _____

Repairs made: _____

Friday - Date: 8-6-21

Condition of vehicle is satisfactory

Vehicle has defects

List defects: _____

Repairs made: _____

Saturday - Date: _____

Condition of vehicle is satisfactory

Vehicle has defects

List defects: _____

Repairs made: _____

End of week odometer reading: _____

Driver Signature: _____

M U T U A L W H E E L C O M P A N Y I N V O I C E

Customer Copy

Page No= 1

Invoice# 4630206

8/07/2021 Cust# CC

MUTUAL WHEEL CO-MONMOUTH
1350 SOUTH MAIN STREET
MONMOUTH IL 61462
309-734-8581

CREDIT CARD
Customer P.O.#
Prepared by RC

Tax Status- TX

Ship Via STORE PICKUP

SOLD-TO
T BELLINGER
MONMOUTH IL 61462

SHIP-TO
MONMOUTH IL

09:47MON 04 IL

qty	ship	b/o	ven	stocking number	description	list	unit	ext	c	it
1	1		795	60700	OVAL GROMMET	3.32	2.48	2.48		1
1	1		689	610CLY	YEL OVAL LED	34.65	17.54	17.54		2

#181

CELEBRATING 126 YEARS 1893-2019.

taxable parts	20.02
Sales Tax	1.85
Invoice Total=	21.87

RECEIVED BY _____ DATE _____

mail remittance to: Mutual Wheel Co., 2345 Fourth Avenue, Moline IL 61265

TERMS: NET 10TH

a 1-1/2% service fee will be charged on past due accounts (18% per annum)
The invoice must accompany returns or no credit will be allowed
20% restocking charge on items returned - no returns after 30 days
No returns on electrical parts or tools. Special orders are non-returnable

WARRANTY DISCLAIMER

Warranties, if any, with respect to these products sold herein are those of the manufacturer only and not those of the seller, Mutual Wheel Co. The Seller hereby expressly disclaims all warranties, expressed or implied including any implied warrant of merchantability or fitness for a particular purpose and the seller neither assumes nor authorizes any other person to assume any liability in connection with the sale of all items.

DMT Express, Inc.

Driver's Vehicle Inspection Report

One report should be turned in weekly for each truck.

Truck #: 181

Odometer: 462 434

Sunday - Date: off

Condition of vehicle is satisfactory

Vehicle has defects

List defects: _____

Repairs made: _____

Monday - Date: 8/2/21

Condition of vehicle is satisfactory

Vehicle has defects

List defects: _____

Repairs made: _____

Tuesday - Date: 8/3/21

Condition of vehicle is satisfactory

Vehicle has defects

List defects: _____

Repairs made: _____

Wednesday - Date: 8/4/21

Condition of vehicle is satisfactory

Vehicle has defects

List defects: _____

Repairs made: _____

Thursday - Date: 8/5/21

Condition of vehicle is satisfactory

Vehicle has defects

List defects: _____

Repairs made: _____

Friday - Date: 8/6/21

Condition of vehicle is satisfactory

Vehicle has defects

List defects: _____

Repairs made: _____

Saturday - Date: off

Condition of vehicle is satisfactory

Vehicle has defects

List defects: _____

Repairs made: _____

End of week odometer reading: 464626

Driver Signature: [Signature] 3355

DMT Express, Inc.
Driver's Vehicle Inspection Report
One report should be turned in weekly for each truck.

Truck #: 181

Odometer: 464626

Sunday - Date: 8/8/21

Condition of vehicle is satisfactory

Vehicle has defects

List defects: _____

Repairs made: _____

Monday - Date: 8/9/21

Condition of vehicle is satisfactory

Vehicle has defects

List defects: _____

Repairs made: _____

Tuesday - Date: 8/10/21

Condition of vehicle is satisfactory

Vehicle has defects

List defects: _____

Repairs made: _____

Wednesday - Date: off

Condition of vehicle is satisfactory

Vehicle has defects

List defects: _____

Repairs made: _____

Thursday - Date: off

Condition of vehicle is satisfactory

Vehicle has defects

List defects: _____

Repairs made: _____

Friday - Date: off

Condition of vehicle is satisfactory

Vehicle has defects

List defects: _____

Repairs made: _____

Saturday - Date: off

Condition of vehicle is satisfactory

Vehicle has defects

List defects: _____

Repairs made: _____

End of week odometer reading: 465214

Driver Signature: [Signature]

1625



Unit ID: 181 ENGINE
 Client ID: S20943 TOOPS TRUCKING
 Unit Type: DIESEL ENGINE
 Unit Make: KENWORTH
 Unit Model: W900
 Component Make: NONE GIVEN
 Component Model: NONE GIVEN

Year
 Lube Type: SCHAEFFER
 Grade: 15W/30
 Capacity:
 Oil Changed: YES

ATTENTION CODE:
Caution

Condition Monitoring Report

REMARKS	*WEAR LEVELS APPEAR NORMAL. *VISCOSITY IS HIGH. SUGGEST INVESTIGATE. *VISCOSITY REPEATED AND VERIFIED. *RESAMPLE AT NORMAL INTERVAL	ATTENTION CODES AAA Acceptable NNN Negative !!! Critical DDD Critical - Below EEE Excessive *** Severe MMM Moderate CCC Severe - Below === Caution BBB Caution - Below --- Slightly Above Normal LLL Slightly Below Normal TTT Trend
----------------	--	--

ASTM D6595 (PPM) WEAR METALS										MULTISOURCE										ADDITIVES			
IRON	CHROMIUM	LEAD	COPPER	TIN	ALUMINUM	NICKEL	SILVER	CADMIUM	VANADIUM	SILICON	BORON	SODIUM	POTASSIUM	MAGNESIUM	TITANIUM	MOLYBDENUM	MANGANESE	LITHIUM	ANTIMONY	CALCIUM	PHOSPHORUS	ZINC	BARIUM
Lab #: 1137648 Dt Tkn: 7/26/2021 Dt Recd: 8/9/2021 HrO: HrU: MiO: 33200 MiU: 459786 Make Up Oil: 20 qts																							
91	2	2	10	1	2	0	0	0	0	6	25	7	7	43	0	59	1	0	0	2030	1037	1182	0

Testing performed at Predictive Maintenance Services. ISO/IEC 17025 accredited laboratory ANAB certificate number AT-2513. This report may not be reproduced in any form except in full. Remarks and comments are advisory only and are based on the assumption that the sample is representative and data submitted is valid. Missing information limits the evaluation. No Warranty is expressed or implied. TOOPS TRUCKING Assumes responsibility for the application of results and recommendations. Measurement uncertainty available upon request. (*) Not in the scope of accreditation. (f) Not in the scope of accreditation and testing outsourced to an approved laboratory.

Client ID: S20943 TOOPS TRUCKING

Unit ID: 181 ENGINE

AN / BN mg KOH/g		VISCOSITY ASTM D445M			CONTAMINANTS					FTIR - abs units	
Acid Number	Base Number	VISC 40c cSt	VISC 100c cSt	VISC INDEX	%WATER	KFISCH (PPM)	FUEL* (FTIR/ASTM D7094)	GLYC (ASTM D2982)	SOOT (ASTM D7844)	OXI (ASTM D7414)	NIT (ASTM D7624)
a = ASTM D974 b = ASTM D664	a = Lab Method WH-038 b = ASTM D4759 c = ASTM D2698*		14.51 ===		<0.1 (a)			N NNN	0.55	18.59	0
					a = Crackle Test k = ASTM D6304a v = ASTM D6304b* o = ASTM D6304c r = Refractometer*						
1137648											

PARTICLE COUNT ISO 4406 - Particles per mL							
	>4(c)	>6(c)	>14(c)	>21(c)	>38(c)	>70(c)	ISO
1137648	0	0	0	0	0	0	#

Reviewed and Approved by: JC

Jared Carbaugh, Analyst

Report Date: 08-12-2021
Barcode:
Date Tested: 08-09-2021 - 08-12-2021

DANNY TOOPS
TOOPS TRUCKING
643 285TH AVE
ALEXIS IL
61412

Testing performed at Predictive Maintenance Services. ISO/IEC 17025 accredited laboratory ANAB certificate number AT-2513. This report may not be reproduced in any form except in full. Remarks and comments are advisory only and are based on the assumption that the sample is representative and data submitted is valid. Missing information limits the evaluation. No Warranty is expressed or implied. TOOPS TRUCKING Assumes responsibility for the application of results and recommendations. Measurement uncertainty available upon request. (*) Not in the scope of accreditation. (#) Not in the scope of accreditation and testing outsourced to an approved laboratory.



120+ Locations in 19 states, mhc.com

SERVICING DEALERSHIP

IOWA KENWORTH, INC., DBA

MHC KENWORTH - QUAD CITIES

3600 78TH AVE WEST

ROCK ISLAND, IL 61201

1-309-787-6181

PARTS INVOICE

Customer No: 215887	Phone: (309) 299-6803	PO#:	Invoice No: T01135600142074
---------------------	-----------------------	------	-----------------------------

Tax Status	Terms	Truck ID	Counter Person	Invoice Date	Due Date
TAXABLE	CHARGE	070506	JIM E	8/12/2021	9/10/2021



S
O
L
D
T
O

Toops Trucking LLC
643 285th Ave
Alexis IL 61412-9157

W900
Truck # 181

S
H
I
P
T
O

DELIVER

Line	Part Number	Description	Ordered	B/O	Shipped	Each	Total
1	GSB11005ATK	GAUGE-SPEE DO ELEC 1	1		1	411.35	411.35

* *Skip the Counter! Text us your part orders at 309-787-6181* *
 * * Online Parts Counter 7/24 Parts Ordering: * *
 * * visit www.mhc.com for details * *

SUBTOTAL	411.35
TAX 8.500 %	34.96
SUBLET	
OTHER	
SHIPPING	



TOTAL DUE	446.31
------------------	---------------

CUSTOMER AUTHORIZATION AND AGREEMENT

1. IMPORTANT: THIS PARTS ORDER AND INVOICE ("Order") CONSISTS OF THE TERMS EXPRESSLY SET FORTH HEREIN AND THE TERMS AND CONDITIONS SET FORTH AT WWW.MHC.COM/DEALERS/TERMS.HTM ("Terms and Conditions") Which are fully incorporated herein by this reference. Execution of this Order shall constitute Customer's agreement to the terms of this Order, including the Terms and Conditions. Customer acknowledges that, upon Customer's request, Customer may obtain a print-out of the Terms and Conditions from Dealer prior to executing this Order. Customer represents that Customer has had an opportunity to read and understand the terms of this Order, including the Terms and Conditions. Customer's acceptance of this Order is limited to Customer's execution of this order as required below, and no contract or agreement for the goods of the Parts and cancels and supersedes all prior negotiations, representations or agreements, either oral or written. Additional or substitute terms will not become part of this Order unless accepted in a writing signed by a corporate officer or authorized manager of Dealer.

2. Returns: Any parts or cores on this Order must be returned within 30 days. No return will be given without a copy of this Order.

3. Authority: The person(s) signing this Order for or on behalf of Customer hereby represents that he/she/they has full authority to bind Customer to this Order.

THIS ORDER CONTAINS A BINDING ARBITRATION PROVISION WHICH MAY BE ENFORCED BY THE PARTIES.

PAY FROM THIS INVOICE
REMIT TO:
 P.O. BOX 879269
 KANSAS CITY, MO 64187-9269

8:41

CUSTOMER AUTHORIZED SIGNATURE

PAGE: 1

Bauer Built

TIRE & SERVICE

BAUER BUILT TIRE
 WEST BURLINGTON 024
 1207 SOUTH BROADWAY STREET

W. BURLINGTON, IA 52655-1620

319/753-2895

INVOICE #: 240095426

PAGE: 1

CUSTOMER: TOOPS TRUCKING LLC
 643 285TH AVENUE

2106278

ALEXIS IL

61412-9157

BUSINESS: 309/299-6803 0

VEHICLE: TRUCK #181

SALESMAN: 24017

MILEAGE: 465334

INVOICE DATE: 08/19/21

DUE: 08/22/21

PRODUCT	MECHANIC	QUANTITY	PRICE	F.E.T.	EXTENSION
STEMCO QWIK KIT KING PIN SET K147E	24021	1	560.77		560.77
HOURLY RATE-TRUCK FM1158A	24021	11.00	94.00		1034.00
3-AXLE ALIGNMENT LABOR TRK FM1156F	24021	1	252.00		252.00
WHEEL ALIGNMENT PARTS 1155	24021	1	10.00		10.00
COURTESY VEHICLE INSPECTION FMINSP	24021	1			0.00
11R225 G XLINE ENERGY Z MI03363		2	513.19	25.23	1076.84
INSTALLATION TRUCK IT	24021	2			0.00
TIRE MOUNT & DISMOUNT LABOR COMM 6803	24021	2	43.00		86.00
ON & OFF VEHICLE LABOR 6804	24021	2	9.00		18.00
METAL VALVE STEM TRUCK 6809	24021	2	7.00		14.00
WHEEL BALANCE PARTS TRK 6824	24021	2	14.00		28.00
WHEEL BALANCE LABOR TRK 6825	24021	2	31.00		62.00
SHOP SUPPLIES 1153		1	5.00		5.00

Thank You for your business. Retorque lug nuts after 50-100 miles.

Payments are due and payable by the 15th day of the month. If payment is not received by the 15th day of the month a FINANCE CHARGE of 1 1/2% per month (ANNUAL PERCENTAGE RATE 18%) on the adjusted balance will be added. The adjusted balance is the previous balance less all payments and credits made since last billing date.

CUSTOMER SIGNATURE _____ PRINT _____

bauerbuilt.com

Bauer Built

TIRE & SERVICE

WEST BURLINGTON 024

INVOICE #: 240095426

PAGE: 2

CUSTOMER: TOOPS TRUCKING LLC

PRODUCT	MECHANIC	QUANTITY	PRICE	F.E.T.	EXTENSION
			MERCHANDISE:		1644.15
			LABOR:		1452.00
			F.E.T.:		50.46
			SALES TAX:		220.26
			INVOICE TOTAL:		3366.87

CHECK

Check Verification #: 3366.87 5077

THANK YOU FOR DOING BUSINESS WITH BAUER BUILT TIRE & SERVICE

Thank You for your business. Retorque lug nuts after 50-100 miles.

Payments are due and payable by the 15th day of the month. If payment is not received by the 15th day of the month a FINANCE CHARGE of 1 1/2% per month (ANNUAL PERCENTAGE RATE 18%) on the adjusted balance will be added. The adjusted balance is the previous balance less all payments and credits made since last billing date.

CUSTOMER SIGNATURE _____ PRINT _____

bauerbuilt.com

Current Measurements

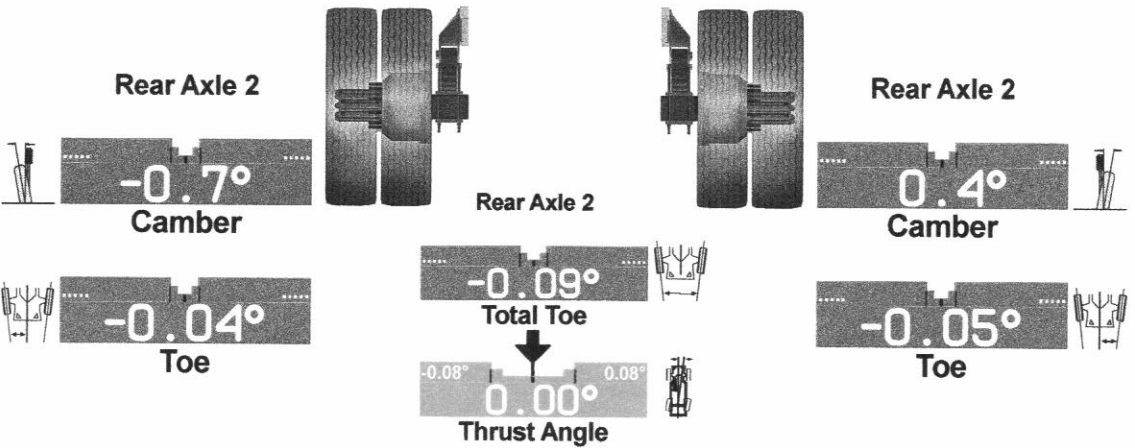
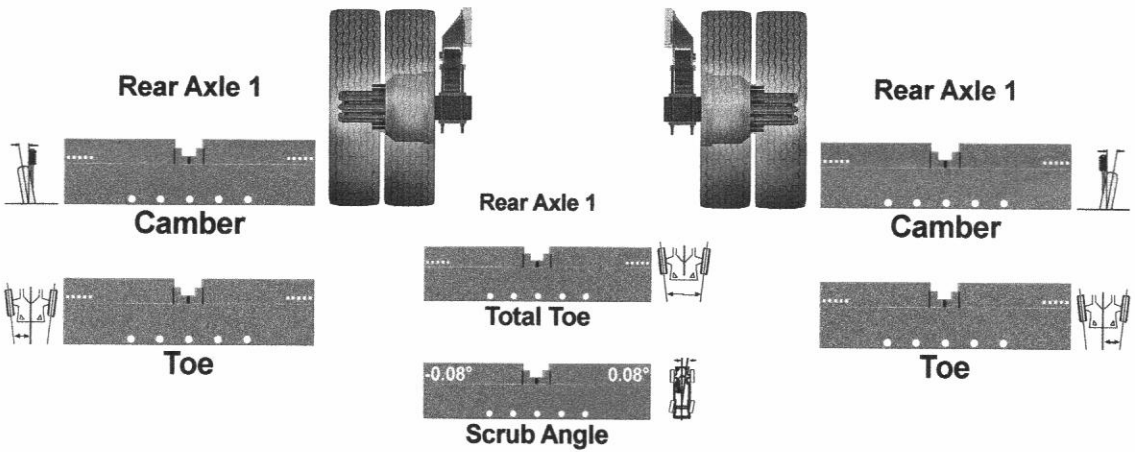
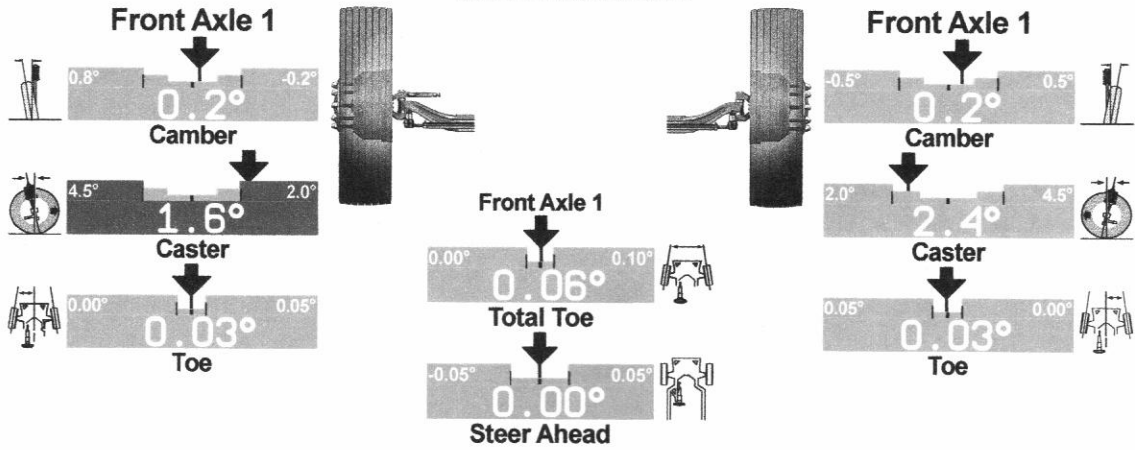



120+ Locations in 19 states, mhc.com

SERVICING DEALERSHIP

IOWA KENWORTH, INC., DBA

MHC KENWORTH - QUAD CITIES

3600 78TH AVE WEST

ROCK ISLAND, IL 61201

1-309-787-6181

PARTS INVOICE

Customer No: 215887	Phone: (309) 299-6803	PO#: 181	Invoice No: T01135600143048
---------------------	-----------------------	----------	-----------------------------

Tax Status	Terms	Truck ID	Counter Person	Invoice Date	Due Date
TAXABLE	CHARGE		DUSTIN R	8/26/2021	9/10/2021



S O L D T O	Toops Trucking LLC 643 285th Ave Alexis IL 61412-9157	S H I P T O	DELIVER
----------------------------	---	----------------------------	---------

Line	Part Number	Description	Ordered	B/O	Shipped	Each	Total
1	480796	SWITCH-T/S ASSY	1		1	214.30	214.30

* *Skip the Counter! Text us your part orders at 309-787-6181* *
 * * Online Parts Counter 7/24 Parts Ordering: * *
 * * visit www.mhc.com for details * *

SUBTOTAL	214.30
TAX 8.500 %	18.22
SUBLET	
OTHER	
SHIPPING	



TOTAL DUE	232.52
------------------	---------------

CUSTOMER AUTHORIZATION AND AGREEMENT

1. IMPORTANT: THIS PARTS ORDER AND INVOICE ("Order") CONSISTS OF THE TERMS EXPRESSLY SET FORTH HEREIN AND THE TERMS AND CONDITIONS SET FORTH AT WWW.MHC.COM/DEALERS/TERMS.HTM ("Terms and Conditions") Which are fully incorporated herein by this reference. Execution of this Order shall constitute Customer's agreement to the terms of this Order, including the Terms and Conditions. Customer acknowledges that, upon Customer's request, Customer may obtain a print-out of the Terms and Conditions from Dealer prior to executing this Order. Customer represents that Customer has had an opportunity to read and understand the terms of this Order, including the Terms and Conditions. Customer's acceptance of this Order is limited to Customer's execution of this order as required below, and no contract or agreement for the goods of and described herein ("Parts") will be formed except parts pursuant to and as permitted by this Order. This Order represents the entire and integrated agreement between the Customer and Dealer regarding the purchase and sale the Parts and cancels and supersedes all prior negotiations, representations or agreements, either oral or written. Additional or substitute terms will not become part of this Order unless accepted in a writing signed by a corporate officer or authorized manager of Dealer.

2. Returns: Any parts or cores on this Order must be returned within 30 days. No return will be given without a copy of this Order.

3. Authority: The person(s) signing this Order for or on behalf of Customer hereby represents that he/she/they has full authority to bind Customer to this Order.

THIS ORDER CONTAINS A BINDING ARBITRATION PROVISION WHICH MAY BE ENFORCED BY THE PARTIES.

PAY FROM THIS INVOICE
REMIT TO:
 P.O. BOX 879269
 KANSAS CITY, MO 64187-9269

9:00 _____
 CUSTOMER AUTHORIZED SIGNATURE

MIDWEST TRUCK SERVICE

305 W. Progress Drive
 Princeton, Illinois 61356
 Shop: 815.875.5867

Date	Invoice #
9/13/2021	23319

PAID
 09/15/2021

Bill To DMT EXPRESS INC PO BOX 316 MONMOUTH, IL 61462 Travis: 309-883-7464	P.O. #/Vin. # 05' Kenworth W900 Vin# 070506 # 181 Unit# 18" Black/Green DOT# 2014886
--	--

Mileage	License #	Year/Make/Model
468,299	P1058776	05' Kenworth

Description	Qty	Item	Rate	Amount
A. Customer called, needs service call to Sheffield. - Unit needs starter. - Loaded up service vehicle and headed towards driver. - Start air compressor and blow dirty oily mess off starter area. NOTES: Noticed that inside bolt is not in all way but is tight. B. Disconnect batteries and remove starter cables. NOTES: Cables showing signs of rubbing along frame rail and through on + cable. - Break bolts loose and remove starter. - Clean up housing with sanding disc. Clean cable ends. - Clean up rusted bolts and work inside bolt back and forth to clean threads. C. Install new starter and tighten. Install cables. - Installed split 2 1/2 radiator hose around + cables at frame and tie strap in place. - Clean ground cable at battery box and install. NOTES: Positive cables should be cleaned. D. Check oil and water level. Oil at least 2 gallon low. E. Check starter operation, OK. Clean up mess and get oil out of truck. - Did not add oil till driver showed up. Asked if he had oil. Told driver unit at least 2 gallon low. Driver added oil and check starter operation, OK. NOTES: This truck could use a washing at motor and a new engine harness.	1	PC1479 STARTER	383.80	383.80T

Thank you for your business!	Subtotal
	ICC # (0.0%)
	Total
	Payments/Credits
	Balance Due

Terms

Midwest truck service shall have a mechanics lien on all vehicles brought in for repair, or road service. until all balances have been paid in full. 2% after 30 days this is annual 24%