

PLAT OF SURVEY

INDEX LEGEND

Property Location: part Lot 1, Section 36, Township 73 North, Range 8 West
Jefferson County, Iowa

Surveyor: Robert H. Lance, Iowa P.L.S. #21980, rob@lancesurveying.com

Return Document to: Lance Surveying Services (319) 986-6779
1505 North Broadway Street, Mt. Pleasant, IA 52641









Survey Requested by: Steffes Group

Proprietor: Peter B Salzman

Survey Completed: 20 August 2021

Sheet 1/1 | Basis of Bearing: IA RTK, ISPS Zone | Salzman, Pete.dwg

Legend:

-  set 1/2"x30" rebar/orange cap #21980
-  found 5/8" rebar
-  found 1/2" rebar
-  set cut X
-  county road R.O.W. line
-  property line
-  road centerline
-  fence line
-  (#) dimension from previous record

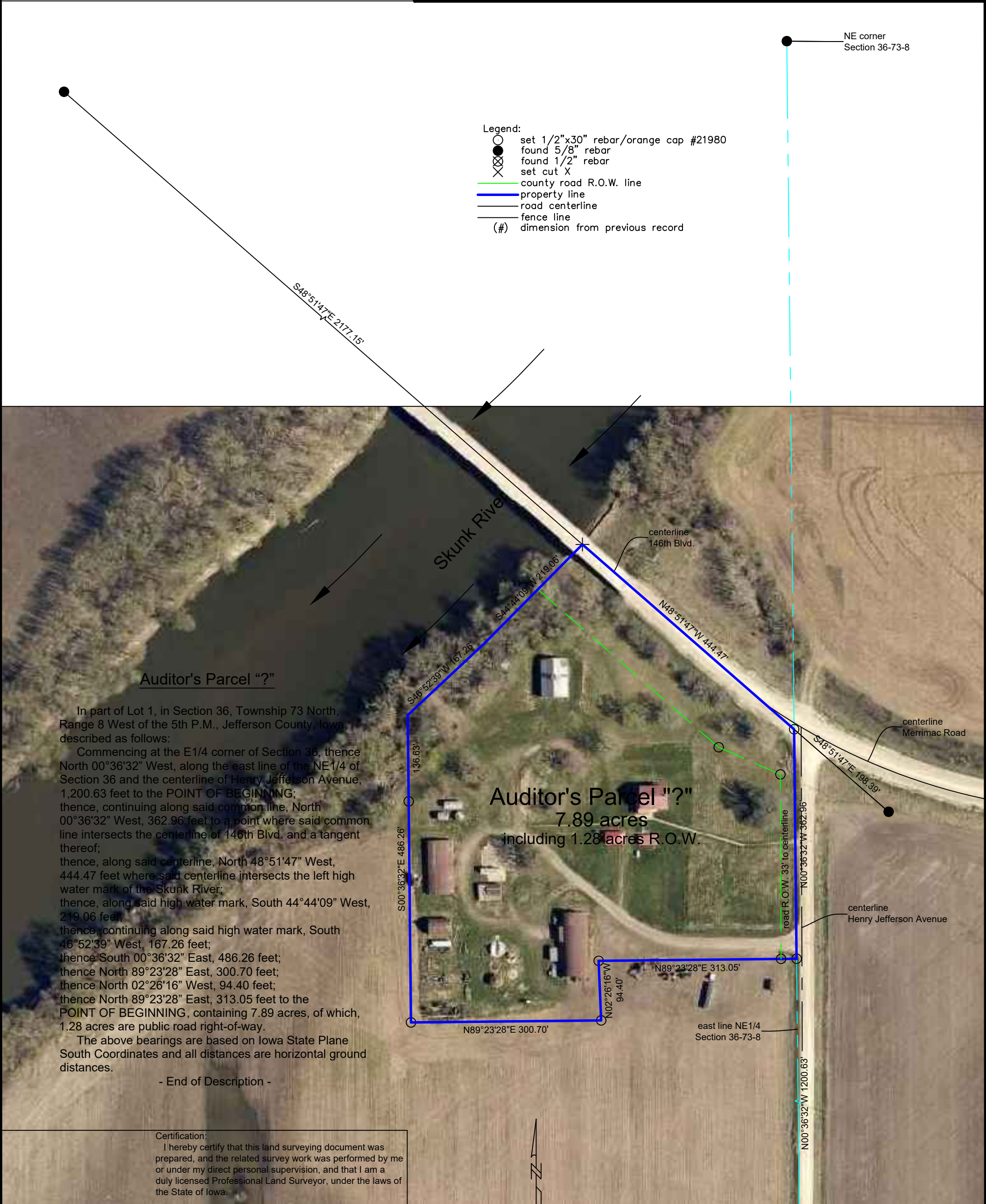

In part of Lot 1, in Section 36, Township 73 North, Range 8 West of the 5th P.M., Jefferson County, Iowa, described as follows:
Commencing at the E1/4 corner of Section 36, thence North 00°36'32" West, along the east line of the NE1/4 of Section 36 and the centerline of Henry Jefferson Avenue, 1,200.63 feet to the POINT OF BEGINNING; thence, continuing along said common line, North 00°36'32" West, 362.96 feet to a point where said common line intersects the centerline of 146th Blvd. and a tangent thereof; thence, along said centerline, North 48°51'47" West, 444.47 feet where said centerline intersects the left high water mark of the Skunk River; thence, along said high water mark, South 44°44'09" West, 219.06 feet; thence, continuing along said high water mark, South 46°52'39" West, 167.26 feet; thence South 00°36'32" East, 486.26 feet; thence North 89°23'28" East, 300.70 feet; thence North 02°26'16" West, 94.40 feet; thence North 89°23'28" East, 313.05 feet to the POINT OF BEGINNING, containing 7.89 acres, of which, 1.28 acres are public road right-of-way.

The above bearings are based on Iowa State Plane South Coordinates and all distances are horizontal ground distances.

- End of Description -

Certification:
I hereby certify that this land surveying document was prepared, and the related survey work was performed by me or under my direct personal supervision, and that I am a duly licensed Professional Land Surveyor, under the laws of the State of Iowa.

Robert H. Lance _____ Date
Iowa Professional Land Surveyor #21980
License renewal date: December 31, 2021
Pages covered by this seal: 1

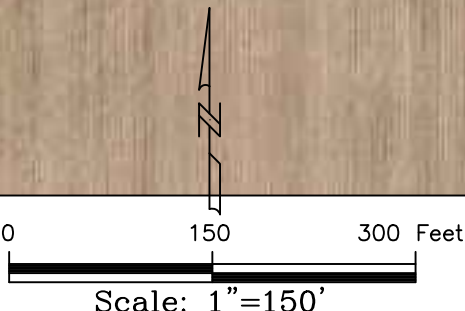

E1/4 corner Section 36-73-8